

MODEL: 02254

ASSEMBLY INSTRUCTIONS

READ AND SAVE THESE INSTRUCTIONS

CAUTION:

HEAVY STONE FOUNTAIN

TWO PEOPLE REQUIRED TO LIFT AND ASSEMBLE

UNPACK THE FOUNTAIN

YOU SHOULD HAVE RECEIVED THE FOLLOWING PARTS: UPPER COLUMN, UPPER RESERVIOR, LOWER COLUMN, PUMP WITH (3) LIGHTS, (3) EXTRA BULBS, LOWER RESERVIOR, BASE, (6) SHIMS AND TRANSFORMER.

FOUNTAIN ASSEMBLY

1. PLACE LOWER RESERVIOR ON TOP OF BASE AND ROTATE THE RESERVIOR TO SECURE.

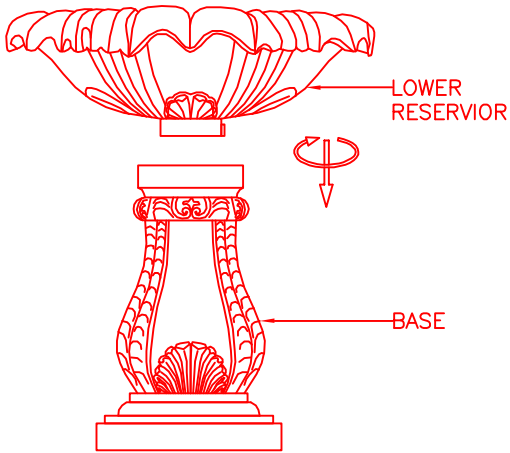

2. FEED THE PUMP POWER CORD THROUGH THE PLASTIC TUBE TOWARD BOTTOM OF BASE, CORD EXITS OUT FROM THE BOTTOM.

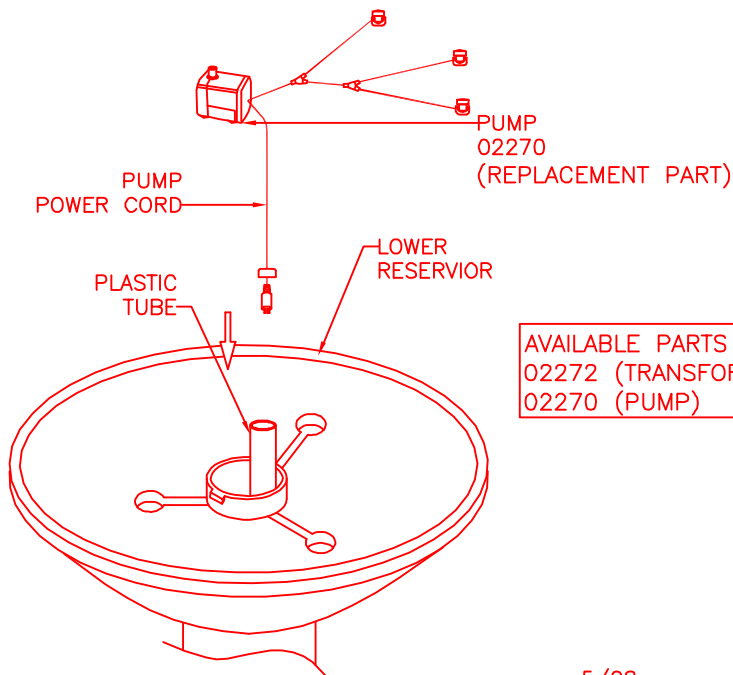

3. PLACE PUMP FLAT IN LOWER RESERVIOR AS SHOWN.

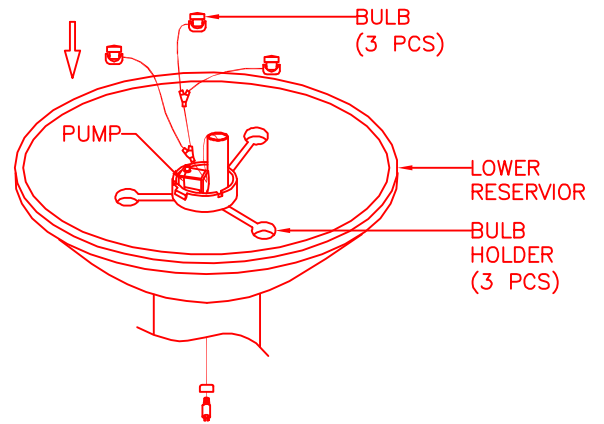

4. PLACE 3-BULBS INTO BULB HOLDERS AS SHOWN.

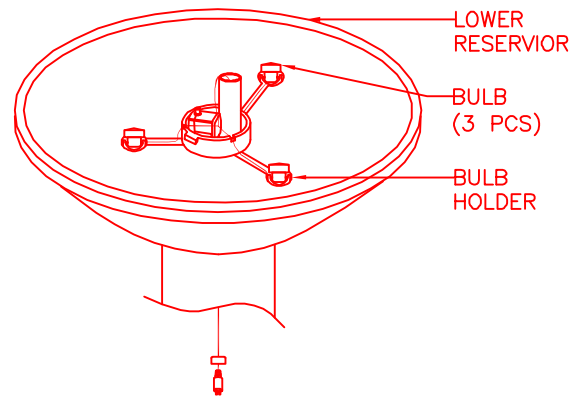

5. PLACE UPPER RESERVIOR ON TOP OF LOWER COLUMN AND ROTATE THE UPPER RESERVIOR TO SECURE.

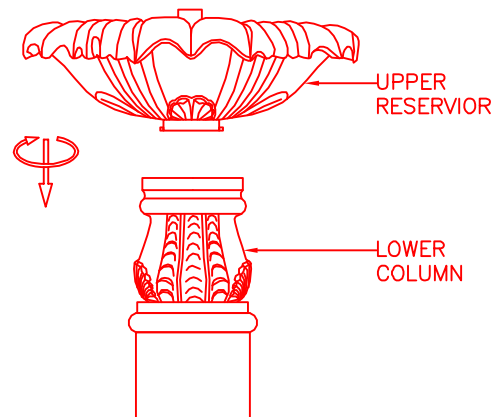

MODEL: 02254

ASSEMBLY INSTRUCTIONS

READ AND SAVE THESE INSTRUCTIONS

FOUNTAIN ASSEMBLY

6. PLACE UPPER COLUMN INTO UPPER RESERVIOR.

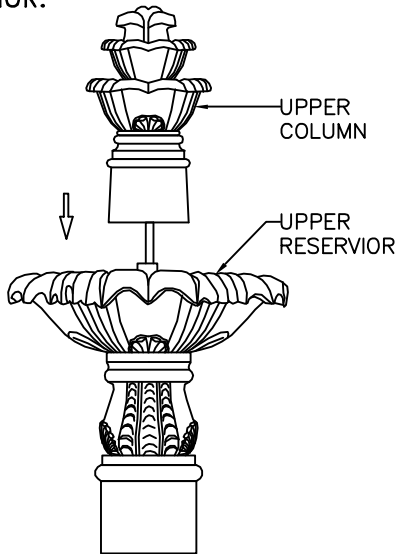

7. LIFT THE UPPER COLUMN, UPPER RESERVIOR AND LOWER COLUMN, ATTACH RUBBER HOSE TO PUMP, THEN PLACE THE UPPER COLUMN, UPPER RESERVIOR AND LOWER COLUMN INTO LOWER RESERVIOR.

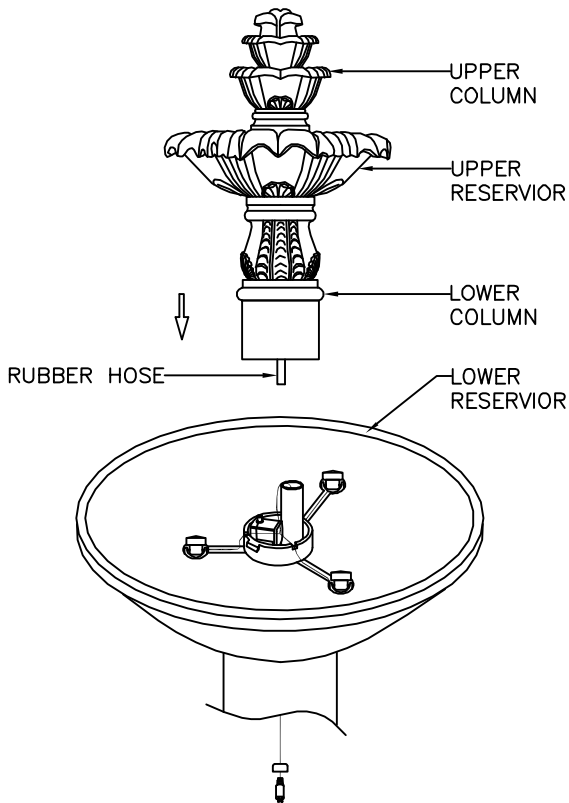

8. FILL LOWER RESERVIOR WITH 7 GALLONS OF WATER TO COMPLETELY SUBMERSE THE PUMP. (DISTILLED WATER IS RECOMMENDED TO REDUCE MINERAL DEPOSITS AND BACTERIA BUILD-UP.)

9. JOIN THE CONNECTORS AT TRANSFORMER AND SCREW THE CAP TO CONNECTOR TIGHTLY TOGETHER.

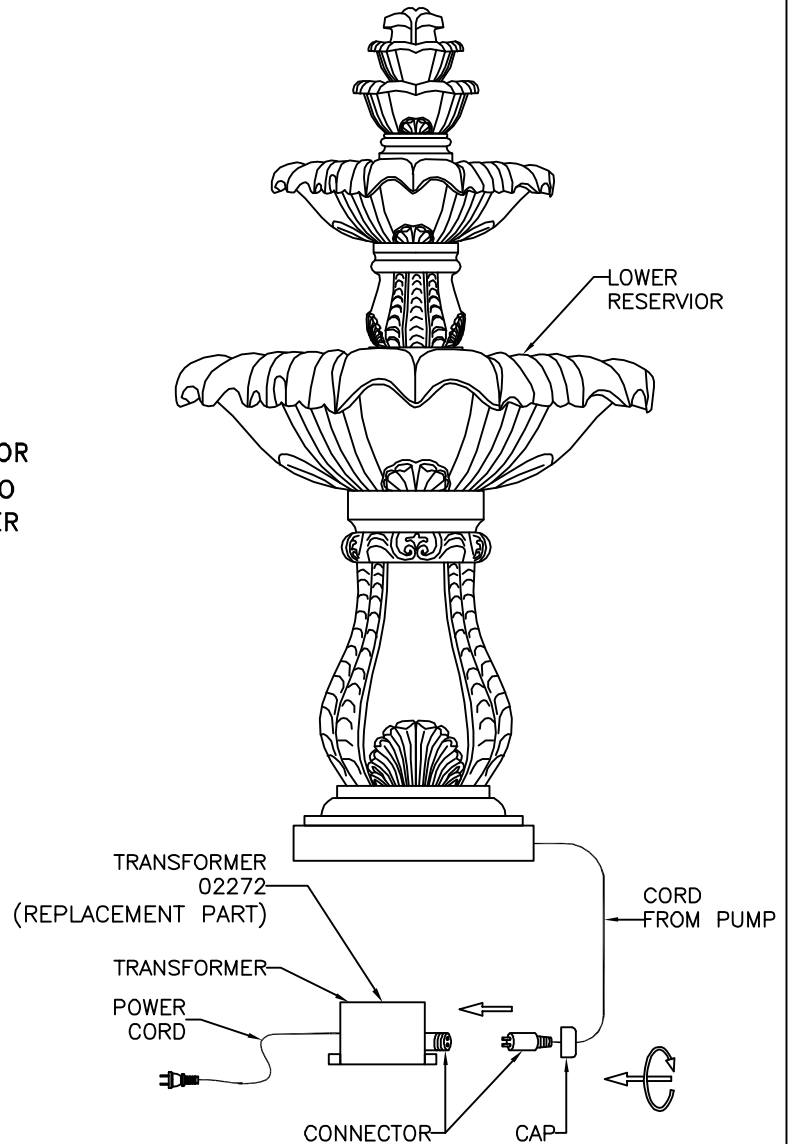

10. PLUG POWER CORD INTO SOCKET, YOUR NEW FOUNTAIN IS READY TO USE.

11. ONCE FOUNTAIN IS RUNNING, USE THE INCLUDED SHIMS TO LEVEL FOR BEST RESULT.

MODEL: 02254

ASSEMBLY INSTRUCTIONS

READ AND SAVE THESE INSTRUCTIONS

TROUBLE SHOOTING:

1. IF YOUR FOUNTAIN DOES NOT WORK, CHECK PLUG AT THE SOCKET. MAKE SURE THE PLUG IS FULLY AND PROPERLY INSERTED INTO THE WALL OUTLET.
2. NEXT CHECK TO MAKE SURE THE OUTLET IS POWERED.
3. IF THE FOUNTAIN STILL DOES NOT WORK, PLEASE CONTACT YOUR DISTRIBUTOR OR PLACE OF PURCHASE.

SPLASHING DISCLAIMER:

SPLASHING MAY OCCUR WHEN FOUNTAIN IS INITIALLY TURNED ON. PROTECT SURROUNDING SURFACES AS NEEDED.

IMPORTANT PUMP INFORMATION:

PUMP MUST BE FULLY SUBMERSED IN WATER WHILE OPERATING.

WATER:

TO REDUCE MINERAL DEPOSITS AND BACTERIA BUILD UP THE USE OF DISTILLED WATER IS RECOMMENDED.

IMPORTANT SAFETY INSTRUCTIONS

THIS FOUNTAIN HAS A POLARIZED PLUG (ONE BLADE IS WIDER THAN THE OTHER) AS A FEATURE TO REDUCE THE RISK OF ELECTRIC SHOCK. THIS PLUG WILL FIT IN A POLARIZED OUTLET ONLY ONE WAY. IF THE PLUG DOES NOT FIT FULLY IN THE OUTLET, REVERSE THE PLUG. IF IT STILL DOES NOT FIT, CONTACT A QUALIFIED ELECTRICIAN. NEVER USE WITH AN EXTENSION CORD UNLESS PLUG CAN BE FULLY INSERTED. DO NOT ALTER THE PLUG.

WARNING:

* ONCE A WEEK INSPECT FOUNTAIN, FLOOR AND ADJACENT WALL FOR MOISTURE BUILD-UP AND CLEAN AS NECESSARY. THIS IS ESPECIALLY IMPORTANT FOR HUMID ENVIRONMENTS.

** HEAVY STONE FOUNTAIN, TWO PEOPLE REQUIRED TO LIFT AND ASSEMBLE.

*** RECOMMENDED FOR OUTDOOR USE ONLY.

**** THIS UNIT MUST BE CONNECTED TO A SUPPLY CIRCUIT THAT IS PROTECTED BY A GROUND FAULT CIRCUIT INTERRUPTER (GFCI). THE GFCI SHOULD BE TESTED ON A ROUTINE BASIS. TO TEST THE GFCI, PUSH THE TEST BUTTON. THE GFCI SHOULD INTERRUPT POWER. PUSH THE RESET BUTTON. POWER SHOULD BE RESTORED. IF THE GFCI FAILS TO OPERATE IN THIS MANNER, THE GFCI IS DEFECTIVE.