

AVAILABLE PARTS ARE:
 50622PMP (PUMP)
 50622TRANS (TRANSFORMER)
 50622SG (SPLASH GUARD)
 50622CLSL (CLOCK AND HANDS)
 50622PENSL (PENDULUM)
 50622BLB (BULB)

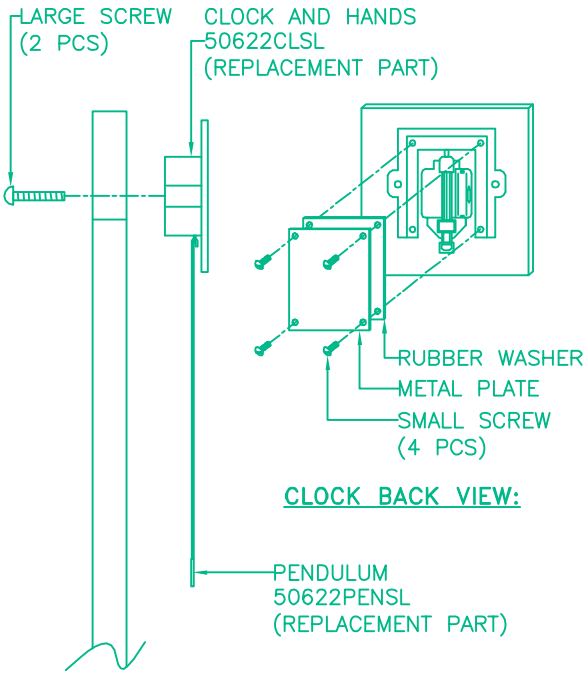

SIDE VIEW:

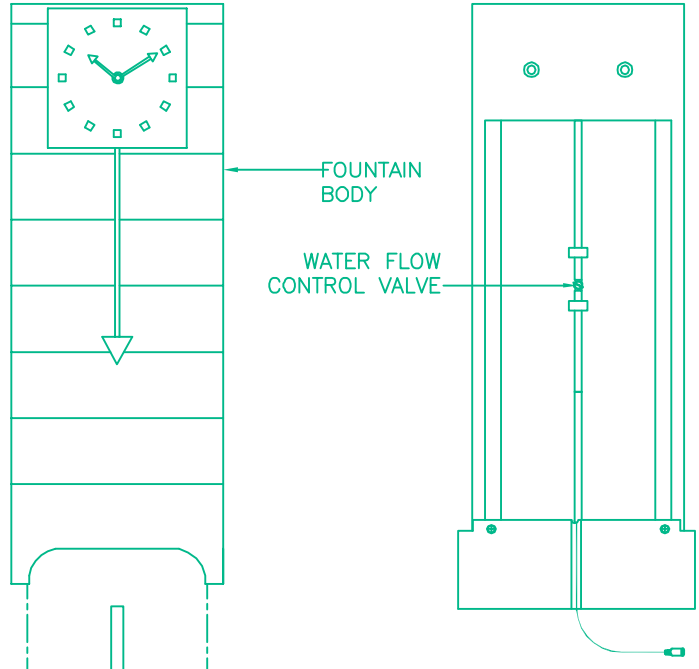

BACK VIEW:

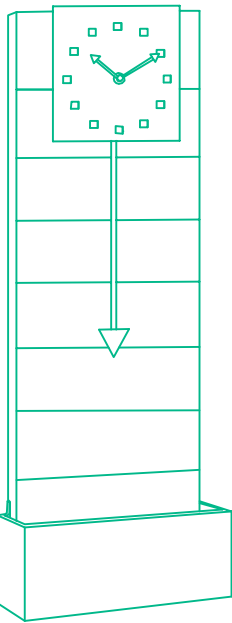

FOUNTAIN ASSEMBLED VIEW:

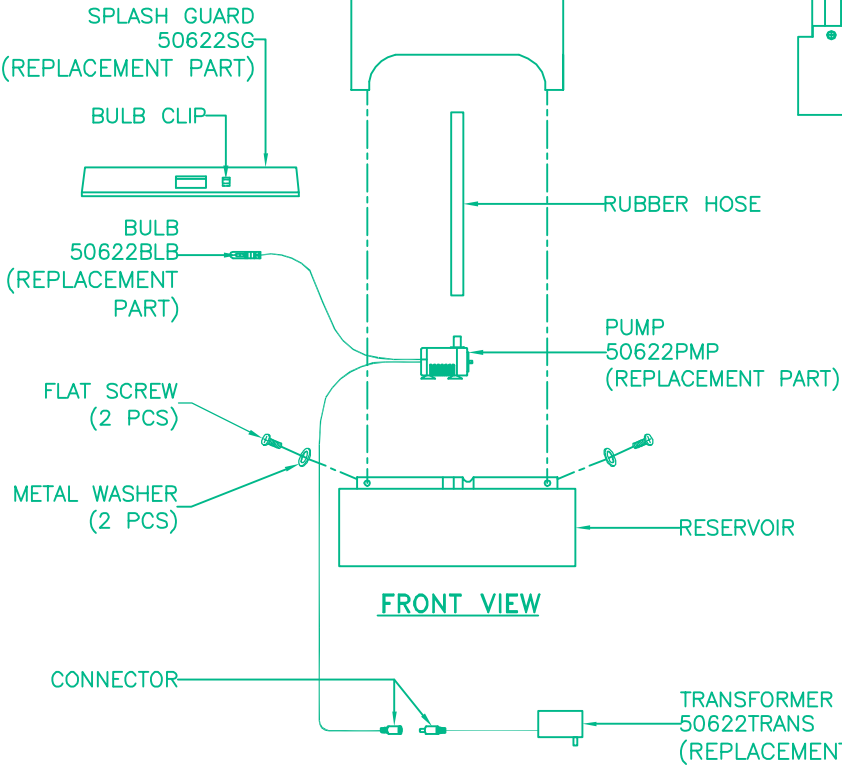

FRONT VIEW

KENROY HOME 11660 CENTRAL PARKWAY JACKSONVILLE, FL. 32224 PHONE: 904-642-4340 FAX: 904-642-4150	THIS DOCUMENT AND THE INFORMATION THAT IT DISCLOSES IS THE EXCLUSIVE PROPERTY OF KENROY HOME. ANY REPRODUCTION OR USE OF THIS DRAWING IN PART OR IN WHOLE, WITHOUT THE EXPRESS CONSENT OF THE PROPRIETOR IS PROHIBITED. © 2009 KENROY HOME.			REVISION DATE: 5/14/09 change pendulum	MODEL #: 50622
	DATE: 4/17/2009	SCALE: NONE	DRAWN BY: JAMES	REVISION DATE:	FINISHES: SL
	REFERENCE: TIDINGS TABLE FOUNTAIN	APPROVAL:	REVISION DATE:	REVISION DATE:	PAGE: 1 OF 2
				REVISION DATE:	
				REVISION DATE:	

PRODUCT SPECIFICATIONS

OVERALL ASSEMBLED DIMENSIONS

HEIGHT: 68.6 CM (27"), WIDTH: 28 CM (11"), EXTENSION: 12.7 CM (5").

PUMP: MODEL: UL-377L, 12V, 60HZ, CLASS 2 POWER UNITS. SUBMERSIBLE FOUNTAIN PUMP.

TRANSFORMER: UL LISTED. INPUT: 120V, 60HZ, OUTPUT: 12V.

1 LIGHT: 12 V. 10 WATT, JC SUBMERSIBLE HALOGEN BULB. (2) BULBS ARE INCLUDED.

FOUNTAIN BODY: PAINTED RESIN WITH NATURAL GREEN SLATE ON THE FRONT SURFACE, 24 CM (9-7/16") WIDTH x 3 CM (1-3/16") EXTENSION x 66 CM (26") HEIGHT, SHAPED AS SHOWN.

CLOCK ASSEMBLY: PAINTED RESIN WITH NATURAL GREEN SLATE ON THE FRONT SURFACE, 16 CM (6-5/16") SQ. x 6 CM (2-3/8") HEIGHT, SHAPED AS SHOWN.

RESERVOIR: PAINTED RESIN (COPPER FINISH), 28 CM (11") WIDTH x 13 CM (5-1/8") EXTENSION x 14 CM (5-1/2") HEIGHT. SHAPED AS SHOWN.

SPLASH GUARD: PAINTED RESIN, 25.5 CM (10") WIDTH x 8 CM (3-1/8") EXTENSION x 1 CM (3/8") THICKNESS, SHAPED AS SHOWN.

CORD: UL LISTED, FROM PUMP TO LIGHT: MIN. 20 CM (7-7/8") LENGTH, FROM PUMP TO CONNECTOR: MIN 183 CM (6 FT.) LENGTH, FROM TRANSFORMER TO CONNECTOR: MIN 100 CM (3-1/4 FT.) LENGTH, BLACK COLOR. WIRES MUST BE LEAD FREE.

DECORATIVE RIVER STONES: A BAG OF RIVER STONES (1.1 LBS.) ARE INCLUDED.

LABELS: MANUFACTURING DATE, MODEL # AND COUNTRY OF ORIGIN LABEL PROVIDED.

PACKAGING AND SHIPPING DETAILS

THE FOUNTAIN IS DISASSEMBLED FOR SHIPPING. THE COMPONENT PARTS ARE CAREFULLY WRAPPED AND PLACED IN THE INNER PACKING SO THAT THEY CAN NOT MOVE DURING SHIPPING. A SMALL BAG OF SILICA IS INCLUDED IN THE PACKAGE.

THE CARTON IS MADE OF DOUBLE WALL CORRUGATED CARDBOARD "A MA A". BROWN IN COLOR. THE INNER PACKING IS DIE-CUT CARDBOARD AND/OR STYROFOAM SUFFICIENT TO PROTECT AND SECURE THE FOUNTAIN AND MUST PASS THE FEDEX DROP TEST REQUIREMENTS.

EACH CARTON SHALL BE PRINTED WITH A LINE DRAWING AND THE KENROY HOME NAME AND LOGO, MODEL NUMBER, SKU NUMBER AND FINISH, EACH CARTON SHALL BE PROVIDED A UPC LABEL. THE UPC BAR CODE AS FOLLOWS: SL=053392106188.

OTHER DETAILS

MODEL 50622SL INSTRUCTIONS ARE TO BE PACKED WITH EACH FOUNTAIN. INSTRUCTIONS MUST BE PRINTED CLEARLY ON QUALITY PAPER.

ALL VISIBLE PARTS MUST MATCH FOUNTAIN FINISH UNLESS OTHERWISE SPECIFIED.

ALL BAGS MUST BE LABELED WITH OFFICIAL "THIS BAG IS NOT A TOY" STATEMENT.

ASSEMBLY TIME: 15 MINUTES.

DIMS OF BOX: 78.7 CM (31") LENGTH x 19 CM (7-1/2") WIDTH x 35.6 CM (14") HEIGHT.

NET WEIGHT: 22 LBS. GROSS WIEGHT: 26.4 LBS.

KENROY HOME 11660 CENTRAL PARKWAY JACKSONVILLE, FL. 32224 PHONE: 904-642-4340 FAX: 904-642-4150	THIS DOCUMENT AND THE INFORMATION THAT IT DISCLOSES IS THE EXCLUSIVE PROPERTY OF KENROY HOME. ANY REPRODUCTION OR USE OF THIS DRAWING IN PART OR IN WHOLE, WITHOUT THE EXPRESS CONSENT OF THE PROPRIETOR IS PROHIBITED. © 2009 KENROY HOME.			REVISION DATE: 5/14/09 change pendulum	MODEL #: 50622
	DATE: 4/17/2009	SCALE: NONE	DRAWN BY: JAMES	REVISION DATE:	FINISHES: SL
	REFERENCE: TIDINGS TABLE FOUNTAIN	APPROVAL:	REVISION DATE:	PAGE: 2 OF 2	
				REVISION DATE:	