

MODEL: 50251SL
ASSEMBLY INSTRUCTIONS
READ AND SAVE THESE INSTRUCTIONS

READ INSTRUCTIONS ALL THE WAY THROUGH PRIOR TO ASSEMBLY.

THIS FOUNTAIN SHOULD TAKE APPROXIMATELY 20 MINUTES TO ASSEMBLE.

MAKE SURE ALL PARTS ARE FIRMLY TIGHTENED.

UNPACK THE FOUNTAIN

YOU SHOULD HAVE RECEIVED THE FOLLOWING PARTS: UPPER LID, UPPER FOUNTAIN BODY, LOWER FOUNTAIN BODY, LOWER LID, FRAME, RESERVOIR, (2) METAL WASHERS, (2) LARGE SCREWS, (2) SMALL SCREWS, PUMP WITH LIGHT, EXTRA HALOGEN BULB, RUBBER HOSE, A BAG OF RIVER STONES AND TRANSFORMER.

FOUNTAIN ASSEMBLY

1. PLACE PUMP FLAT IN RESERVOIR, THEN RUN PUMP POWER CORD UP AND OVER BACK OF RESERVOIR.

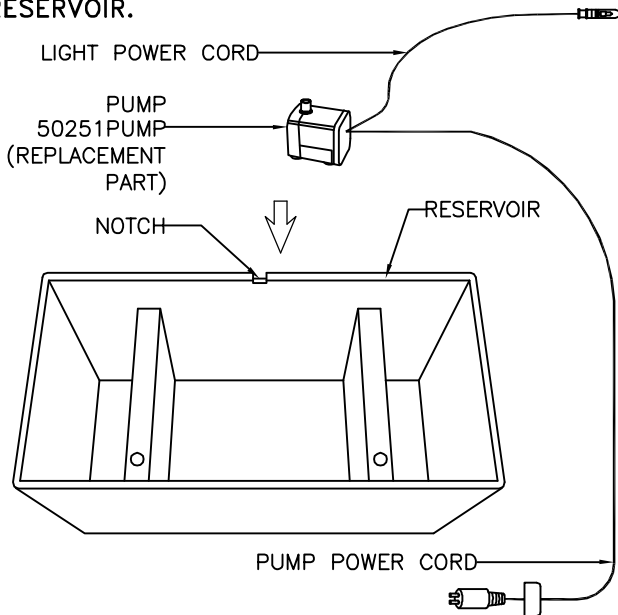

2. ATTACH RUBBER HOSE TO THE PUMP.

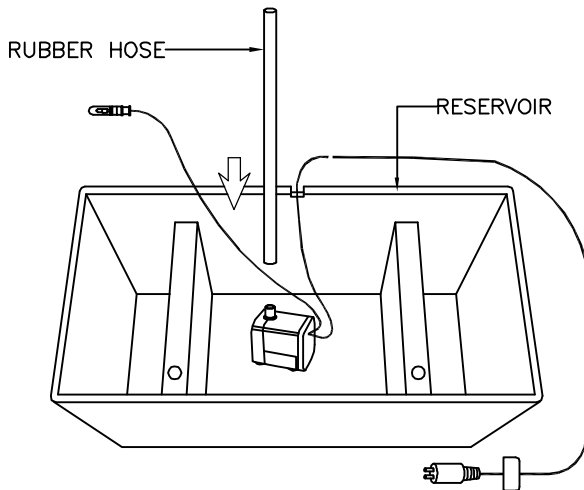

3. PLACE FRAME ONTO THE RESERVOIR. MAKE SURE PUMP POWER CORD SITS IN THE NOTCH.

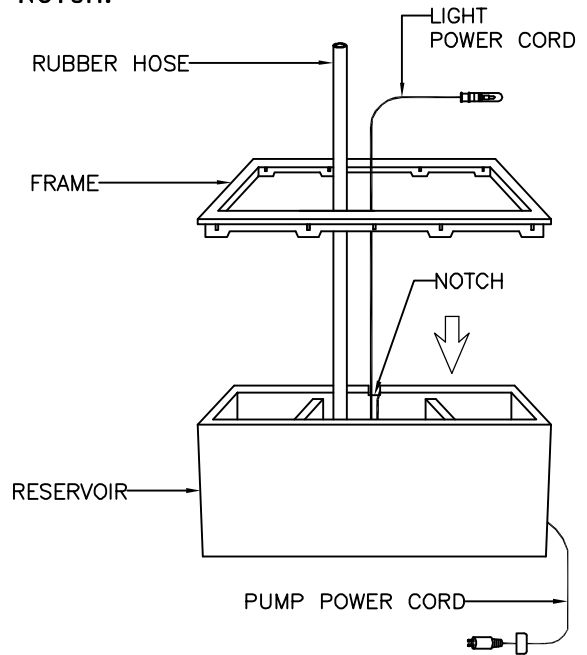

4. FEED RUBBER HOSE UP THROUGH HOLE IN BACK OF THE LOWER FOUNTAIN BODY. PLACE LOWER FOUNTAIN BODY INTO RESERVOIR, THEN SECURE WITH (2) METAL WASHERS AND (2) LARGE SCREWS.

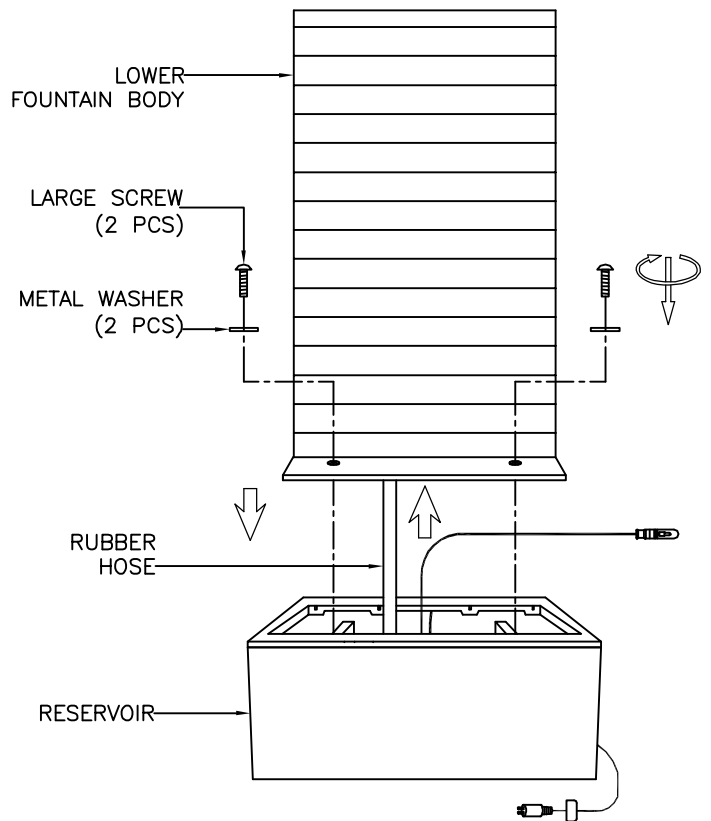

MODEL: 50251SL
ASSEMBLY INSTRUCTIONS
READ AND SAVE THESE INSTRUCTIONS

5. INSERT PINS OF UPPER FOUNTAIN BODY INTO THE HOLES OF LOWER FOUNTAIN BODY, THEN SECURE WITH (2) SMALL SCREWS FROM BACK OF THE LOWER FOUNTAIN BODY.

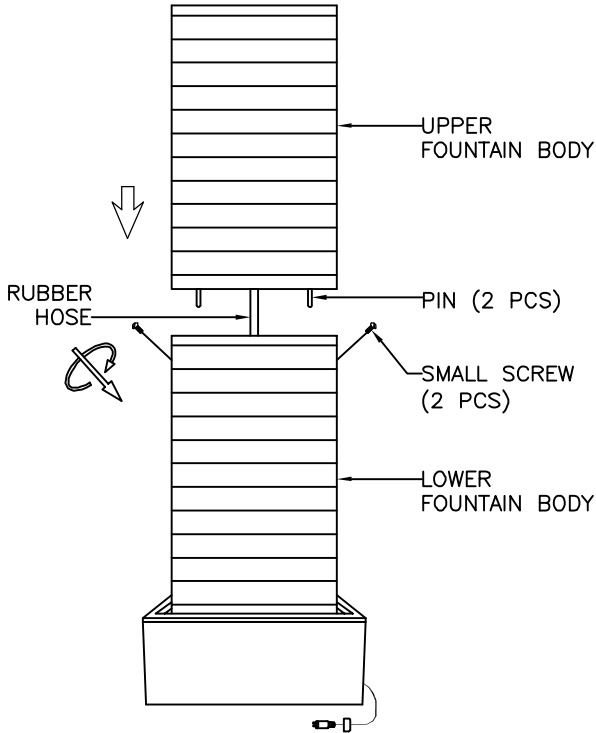

6. JOIN THE RUBBER HOSES TOGETHER FROM BACK OF THE FOUNTAIN BODY.

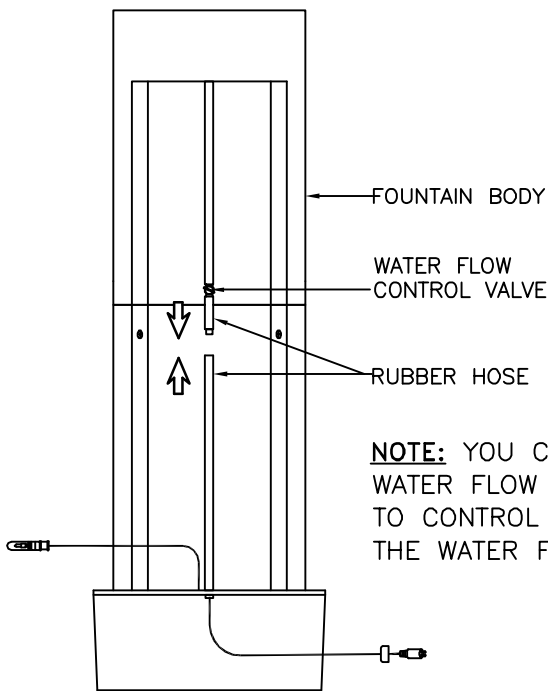

NOTE: YOU CAN ADJUST THE WATER FLOW CONTROL VALVE TO CONTROL THE SPEED OF THE WATER FLOW.

BACK VIEW:

7. FEED LIGHT POWER CORD UP THROUGH HOLE IN FOUNTAIN BODY AND WORKING UPWARDS TOWARD TOP OF THE FOUNTAIN BODY.

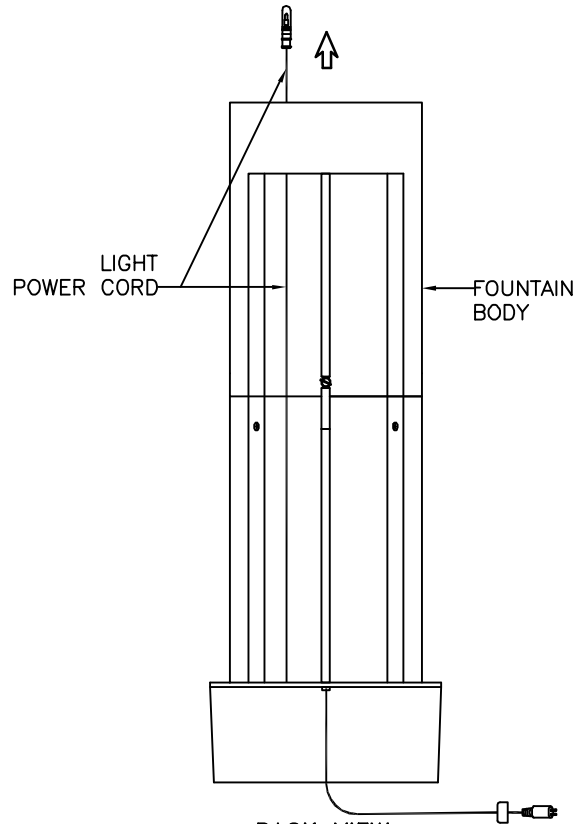

BACK VIEW:

8. ATTACH BULB TO BULB CLIP ON UPPER LID. THEN PLACE UPPER LID ON TOP OF FOUNTAIN BODY.

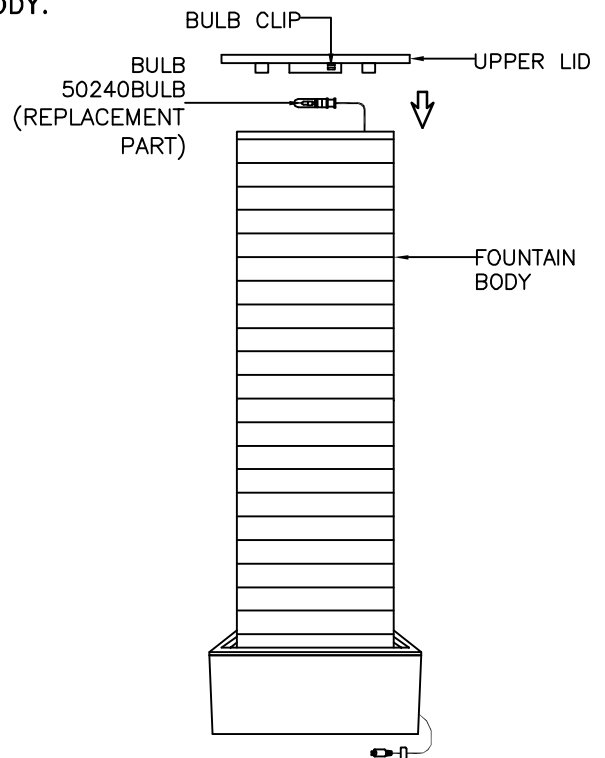

MODEL: 50251SL
ASSEMBLY INSTRUCTIONS
 READ AND SAVE THESE INSTRUCTIONS

9. FILL RESERVOIR WITH 2.5 GALLONS OF WATER TO COMPLETELY SUBMERSE THE PUMP.

NOTE: DISTILLED WATER IS RECOMMENDED TO REDUCE MINERAL DEPOSITS AND BACTERIA BUILD-UP.

10. PLACE LOWER LID IN RESERVOIR TO COVER THE RESERVOIR.

11. PLACE DECORATIVE RIVER STONES ONTO TOP OF LOWER LID.

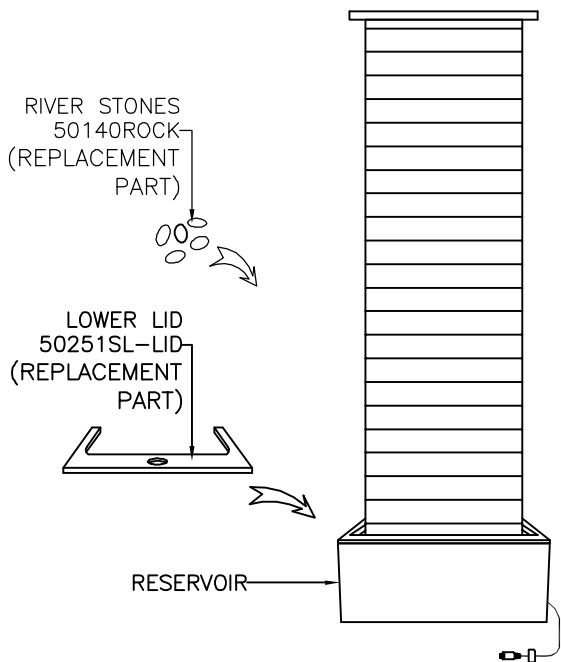

12. JOIN THE CONNECTORS AT TRANSFORMER AND SCREW THE CAP TIGHTLY TOGETHER.

13. PLUG POWER CORD INTO OUTLET, YOUR NEW FOUNTAIN IS READY FOR USE.

AVAILABLE PARTS ARE:
 50251TRANS (TRANSFORMER)
 50251PUMP (PUMP)
 50240BULB (BULB)
 50140ROCK (RIVER STONE)
 50251SL-LID (LOWER LID)

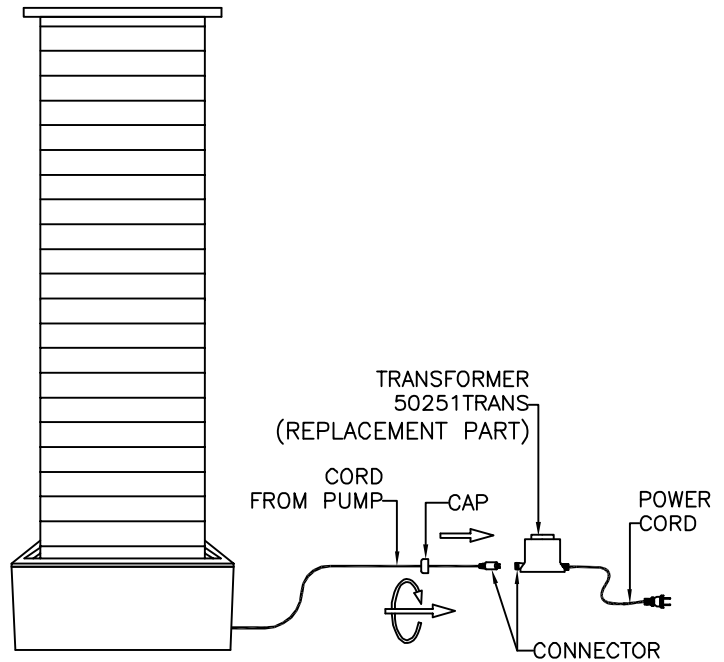

TROUBLE SHOOTING:

1. IF YOUR FOUNTAIN DOES NOT WORK, CHECK PLUG AT THE SOCKET. MAKE SURE THE PLUG IS FULLY AND PROPERLY INSERTED INTO THE WALL OUTLET.
2. NEXT CHECK TO MAKE SURE THE OUTLET IS POWERED.
3. IF THE FOUNTAIN STILL DOES NOT WORK, PLEASE CONTACT YOUR DISTRIBUTOR OR PLACE OF PURCHASE.

SPLASHING DISCLAIMER:

SPLASHING MAY OCCUR WHEN FOUNTAIN IS INITIALLY TURNED ON. PROTECT SURROUNDING SURFACES AS NEEDED.

IMPORTANT PUMP INFORMATION:

PUMP MUST BE FULLY SUBMERSED IN WATER WHILE OPERATING.

WATER:

TO REDUCE MINERAL DEPOSITS AND BACTERIA BUILD UP THE USE OF DISTILLED WATER IS RECOMMENDED.

IMPORTANT SAFETY INSTRUCTIONS:

THIS FOUNTAIN HAS A POLARIZED PLUG (ONE BLADE IS WIDER THAN THE OTHER) AS A FEATURE TO REDUCE THE RISK OF ELECTRIC SHOCK. THIS PLUG WILL FIT IN A POLARIZED OUTLET ONLY ONE WAY. IF THE PLUG DOES NOT FIT FULLY IN THE OUTLET, REVERSE THE PLUG. IF IT STILL DOES NOT FIT, CONTACT A QUALIFIED ELECTRICIAN. NEVER USE WITH AN EXTENSION CORD UNLESS PLUG CAN BE FULLY INSERTED. DO NOT ALTER THE PLUG.

WARNING:

* ONCE A WEEK INSPECT FOUNTAIN, FLOOR AND ADJACENT WALL FOR MOISTURE BUILD-UP AND CLEAN AS NECESSARY. THIS IS ESPECIALLY IMPORTANT FOR HUMID ENVIRONMENTS.
 ** THIS FOUNTAIN IS RATED FOR INDOOR & OUTDOOR USE.
 *** THIS UNIT MUST BE CONNECTED TO A SUPPLY CIRCUIT THAT IS PROTECTED BY A GROUND FAULT CIRCUIT INTERRUPTER (GFCI). THE GFCI SHOULD BE TESTED ON A ROUTINE BASIS. TO TEST THE GFCI, PUSH THE TEST BUTTON. THE GFCI SHOULD INTERRUPT POWER. PUSH THE RESET BUTTON. POWER SHOULD BE RESTORED. IF THE GFCI FAILS TO OPERATE IN THIS MANNER, THE GFCI IS DEFECTIVE.